

1. George used a decorative gate to connect the fencing around his backyard.

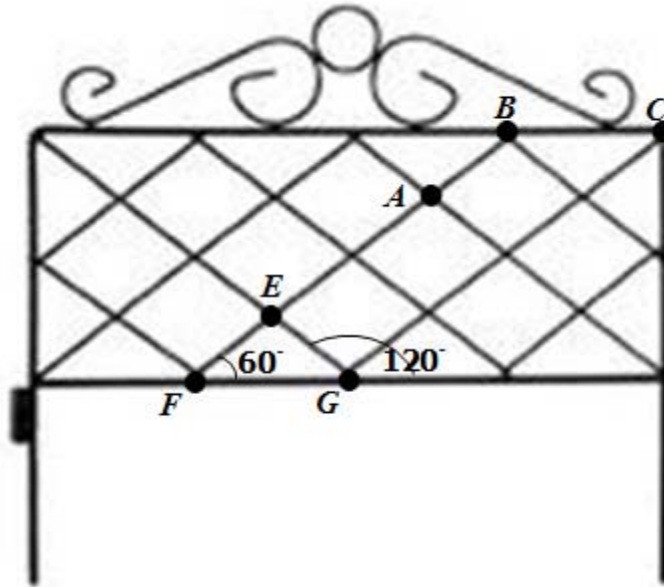

Using the information on the diagram and assuming the top and bottom are parallel, $m\angle ABC$ is —

- A) 40°
 - B) 60°
 - C) 120°
 - D) 180°
2. Given: $p \parallel q$, $m \parallel n$, and $m\angle 1 = 75^\circ$.

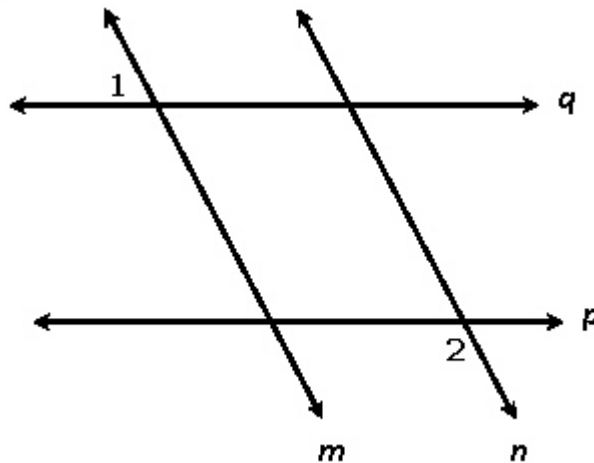

What is $m\angle 2$?

- A) 15°
- B) 75°
- C) 105°
- D) 165°

3. Determine which statement best represents the information in the figure.

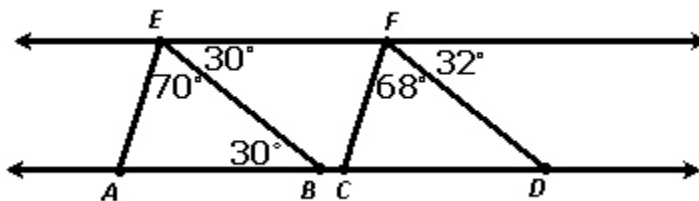

- A) $\overline{AE} \parallel \overline{CF}$ and $\overline{EB} \parallel \overline{FD}$
- B) $\overline{AD} \parallel \overline{EF}$ and $\overline{EB} \parallel \overline{FD}$
- C) $\overline{AD} \parallel \overline{EF}$ and $\overline{CF} \parallel \overline{FD}$
- D) $\overline{AE} \parallel \overline{CF}$ and $\overline{EF} \parallel \overline{AD}$

4. Given: $k \parallel p$.

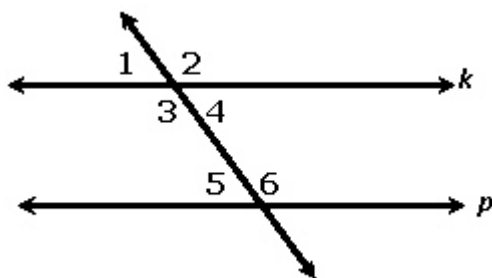

Which of the following is NOT a valid proof that $m\angle 1 + m\angle 6 = 180^\circ$?

- A)

Statements	Reasons
1. $k \parallel p$	1. Given
2. $m\angle 1 = m\angle 5$	2. If two parallel lines are cut by a transversal, corresponding angles are congruent
3. $m\angle 5 + m\angle 6 = 180^\circ$	3. Definition of linear pair
4. $m\angle 1 + m\angle 6 = 180^\circ$	4. Substitution property
- B)

Statements	Reasons
1. $k \parallel p$	1. Given
2. $m\angle 1 = m\angle 4$	2. Definition of vertical angles.
3. $m\angle 4 + m\angle 6 = 180^\circ$	3. If two parallel lines are cut by a transversal, same side interior angles are supplementary
4. $m\angle 1 + m\angle 6 = 180^\circ$	4. Substitution property

C)

Statements	Reasons
1. $k \parallel p$	1. Given
2. $m\angle 1 + m\angle 2 = 180^\circ$	2. If two parallel lines are cut by a transversal, alternate exterior angles are supplementary
3. $m\angle 2 = m\angle 6$	3. If two parallel lines are cut by a transversal, corresponding angles are congruent
4. $m\angle 1 + m\angle 6 = 180^\circ$	4. Substitution property

D)

Statements	Reasons
1. $k \parallel p$	1. Given
2. $m\angle 1 + m\angle 3 = 180^\circ$	2. Definition of linear pair
3. $m\angle 3 = m\angle 6$	3. If two parallel lines are cut by a transversal, alternate interior angles are congruent
4. $m\angle 1 + m\angle 6 = 180^\circ$	4. Substitution property

5. If $p \parallel q$, what is the measure of $\angle ACB$?

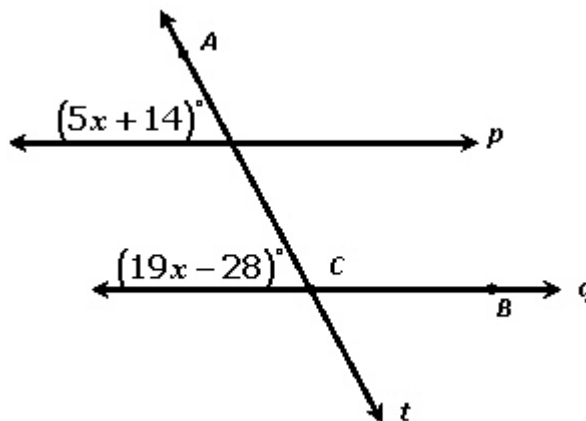

- A) 3°
- B) 29°
- C) 151°
- D) 177°

6. Given: \overline{LM} and \overline{QR} are parallel.
 Given: $m\angle M = m\angle L = 50^\circ$.

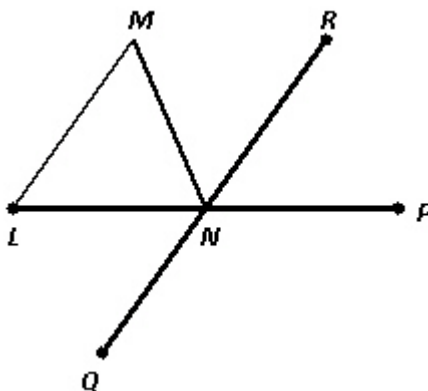

What is $m\angle QNP$?

- A) 130°
- B) 100°
- C) 80°
- D) 50°

7. Scott is constructing a line perpendicular to line l from point P . Which of the following should be his first step?

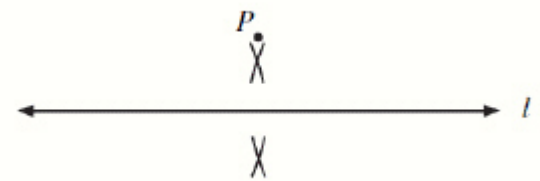
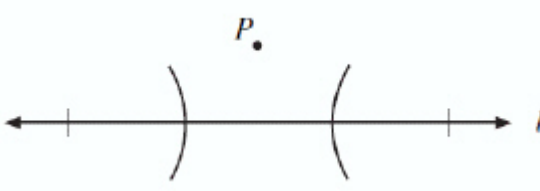
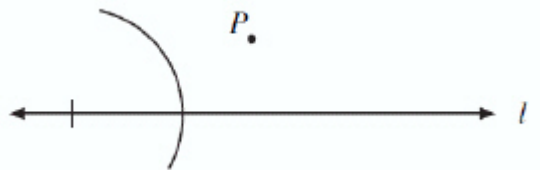
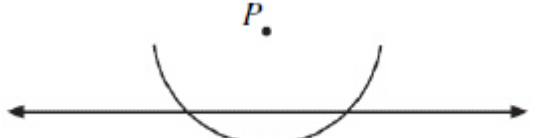
- A) 
- B) 
- C) 
- D) 

8. Given: angle A

What is the first step in constructing the angle bisector of angle A ?

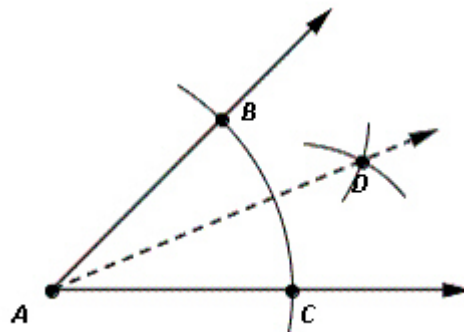

- A) Draw \overline{AD} .
- B) Draw a line segment connecting points B and C.
- C) From points B and C, draw equal arcs that intersect at D.
- D) From point A, draw an arc that intersects the sides of the angle at points B and C.

9. Which geometric construction is shown in the diagram?

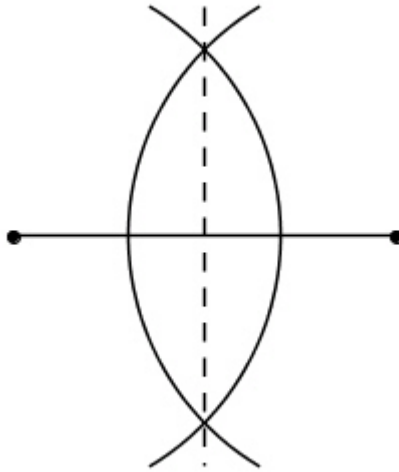

- A) a line segment congruent to a given line segment.
 B) a line parallel to a given line
 C) a perpendicular bisector of a segment
 D) a bisector of a given angle
10. Which conclusion logically follows the true statements?

“If the football team doesn’t score, they will lose the game.”

“If the football team loses the game, they will not play for the championship.”

- A) If the football team wins, they will not play for the championship.
 B) If the football team scores, they will play for the championship.
 C) If the football team doesn’t score, they will play for the championship.
 D) If the football team doesn’t score, they will not play for the championship.
11. Based strictly on this diagram representing students participating in after school activities, which statement represents the shaded region?

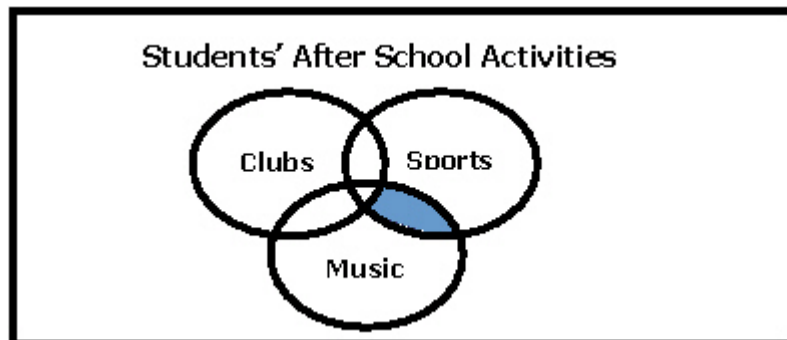

- A) Some students participate in sports and music, but not clubs.
 B) Some students participate in clubs and music, but not sports.
 C) Some students participate in sports, music, and clubs.
 D) All students participate in sports and music.

12. Consider the following statements represented by p and q :

p : The sum of two angles is 180° .

q : The two angles are supplements.

Which of the following is a symbolic representation of the statement

If two angles are not supplements, then the sum of the two angles is not 180° .

- A) $q \rightarrow p$
 - B) $p \rightarrow q$
 - C) $\sim q \rightarrow \sim p$
 - D) $\sim p \rightarrow \sim q$
13. Which is the biconditional of the following statement?

If a polygon is a triangle, then it has exactly three sides.

- A) A polygon is not a triangle if and only if it does not have three sides.
 - B) A polygon is a triangle if and only if it has exactly three sides.
 - C) If a polygon has exactly three sides, then it is a triangle.
 - D) If a polygon does not have exactly three sides, then it is not a triangle.
14. Quadrilateral $ABCD$ has vertices $A (-2,2)$, $B (4,5)$, $C(3,0)$ and $D (-3,-3)$. What are the coordinates of the midpoint of diagonal \overline{BD} ?

- A) $\left(\frac{1}{2}, -1\right)$
- B) $\left(\frac{1}{2}, 1\right)$
- C) $\left(1, \frac{1}{2}\right)$
- D) $(1, 1)$

15. If triangle XYZ is reflected across the x -axis to form triangle $X'Y'Z'$, what are the coordinates of Z' ?

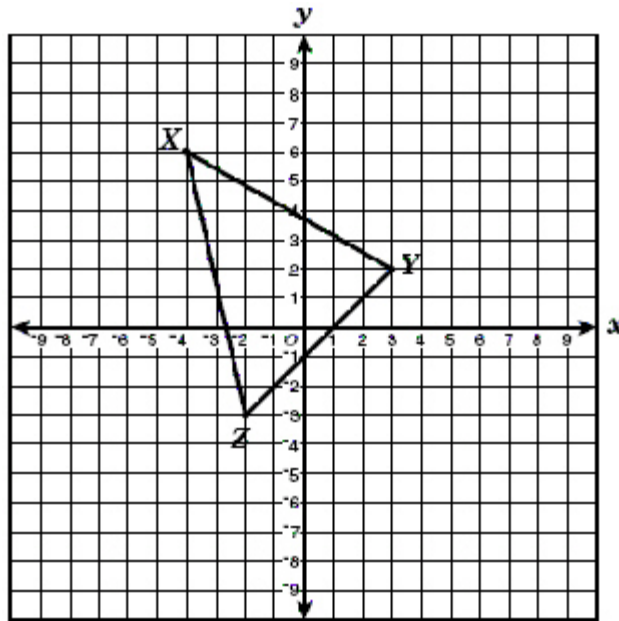

- A) (2, -3)
- B) (2, 3)
- C) (-2, 3)
- D) (3, 2)

16.



This figure has —

- A) point symmetry only
 - B) line symmetry only
 - C) point and line symmetry
 - D) neither point nor line symmetry
17. In the diagram, $\Delta A' B' C'$ is a transformation of ΔABC , and $\Delta A'' B'' C''$ is a transformation of $\Delta A' B' C'$.

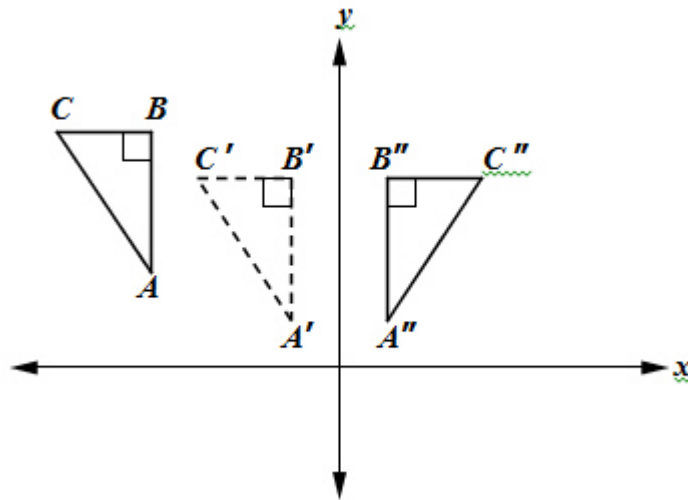

The composite transformation of $\triangle ABC$ to $\triangle A''B''C''$ is an example of a

- A) reflection followed by a rotation.
- B) reflection followed by a translation.
- C) translation followed by a rotation.
- D) translation followed by a reflection.

18. The equation of line k is $y = \frac{1}{3}x - 2$.

The equation of line m is $-2x + 6y = 18$.

Lines k and m are –

- A) parallel
- B) perpendicular
- C) the same line
- D) intersecting but not perpendicular

19.

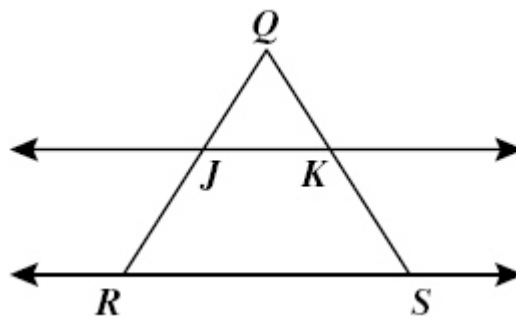

$\triangle QJK \sim \triangle QRS$.

Which of the following statements is NOT true?

- A) $\frac{QJ}{QR} = \frac{QK}{QS}$
- B) $\frac{JK}{RS} = \frac{QK}{QS}$

- C) $\frac{QR}{JK} = \frac{QS}{RJ}$
- D) $\frac{QR}{QS} = \frac{QJ}{QK}$

20. In the following diagram, it is given that C is the midpoint of \overline{BD} , that $\overline{AB} \perp \overline{BD}$, and that $\overline{BD} \perp \overline{DE}$.

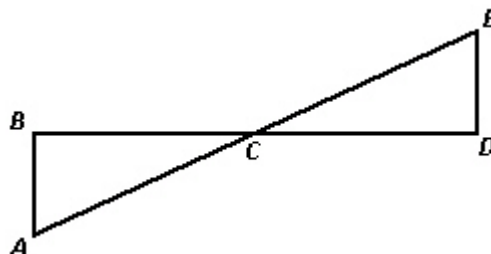

Prove $\triangle ABC \cong \triangle EDC$ by selecting the most logical sequence of statements and reasons.

Statements	Reasons
1. C is a midpoint of \overline{BD}	1. Given
2. $\overline{BC} \cong \overline{CD}$	2. Definition of Midpoint
3. $\angle BCA \cong \angle ECD$	3. Vertical angles are congruent
4. $\overline{AB} \perp \overline{BD}$ and $\overline{BD} \perp \overline{DE}$	4. Given
5. $\angle ABC$ and $\angle EDC$ are right angles	5. _____
6. $\angle ABC \cong \angle EDC$	6. _____
7. $\triangle ABC \cong \triangle EDC$	7. _____

- A) 5. Definition of perpendicular lines
6. All right angles are congruent
7. Angle-Side-Angle (ASA)
- B) 5. Given
6. All right angles are congruent
7. Angle-Side-Angle (ASA)
- C) 5. Definition of congruent angles
6. All right angles are congruent
7. Side-Angle-Side (SAS)
- D) 5. Definition of perpendicular lines
6. Alternate interior angles are congruent
7. Right triangles are congruent to each other

21. For what value of x is $\triangle ABC \sim \triangle DEF$?

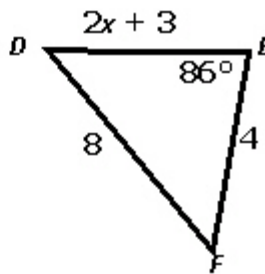
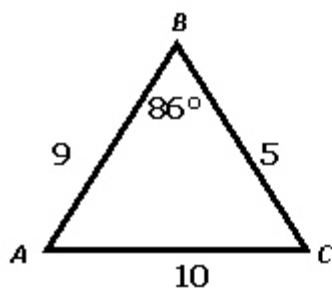

- A) 2
- B) 2.1
- C) 2.5
- D) 4.125

22. Select all sets of given triangle lengths that would form a right triangle.

I. 3, 4, 6	III. 11, 60, 61	V. 7, 24, 25
II. 8, 15, 17	IV. 5, 7, 12	VI. 12, 15, 18

- A) II, IV, V
- B) II, III, V
- C) I, V, VI
- D) IV only

23. Which set of lengths could be the lengths of the sides of a triangle?

- A) 1, 2, 3
- B) 6, 6, 14
- C) 7, 24, 25
- D) 10, 20, 33

24. Roof designs often use right triangles to make a structure more rigid to hold up the weight of the roof. If a house is 40 feet wide and the roof is an isosceles triangle with base angles of 30 degrees, how far is it from the bottom edge of the roof to the peak?

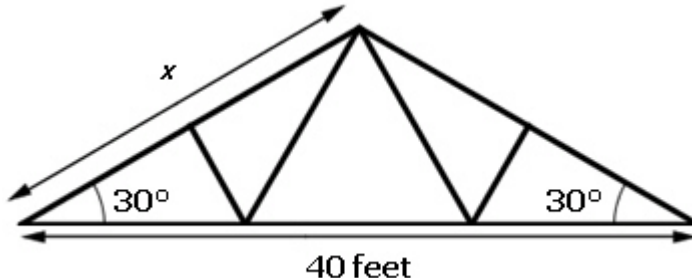

- A) $\frac{40\sqrt{3}}{3}$ ft
- B) $\frac{20\sqrt{3}}{3}$ ft
- C) $20\sqrt{3}$ ft
- D) 40 ft

25. On a map, Richmond, Danville, and Charlottesville form a triangle. Charlottesville is 85 miles from Richmond and Danville is 100 miles from Richmond. Which is a possible distance between Danville and Charlottesville?
- A) 5 miles
 B) 15 miles
 C) 150 miles
 D) 185 miles
26. In scalene triangle ABC , $m\angle B = 45^\circ$ and $m\angle C = 55^\circ$. What is the order of the sides in length, from longest to shortest?
- A) $\overline{AB}, \overline{BC}, \overline{AC}$
 B) $\overline{BC}, \overline{AC}, \overline{AB}$
 C) $\overline{AC}, \overline{BC}, \overline{AB}$
 D) $\overline{BC}, \overline{AB}, \overline{AC}$
27. Pedro has a square practice net in his backyard. The diagonal of the net is 6 feet. Find the length of one side of the net.
- A) $3\sqrt{2}$ feet
 B) $2\sqrt{3}$ feet
 C) 3 feet
 D) 12 feet
28. A surveyor is trying to determine the width of a river. He first stands at point A , directly opposite a tree at point B . He then walks 100 feet to point C . He measures the acute angle at point C to be 79° . What is the width, w , of the river?

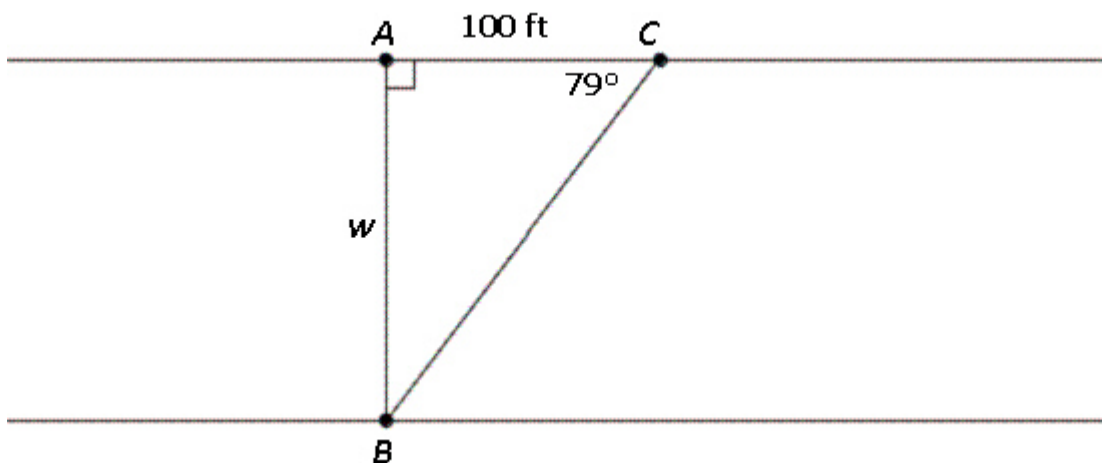

- A) 19.4 feet
 B) 101.87 feet
 C) 514.5 feet
 D) 524.1 feet

29. From the top of a lighthouse 210 feet high, the angle of depression to a boat is 27° . Find the distance from the boat to the base of the lighthouse.

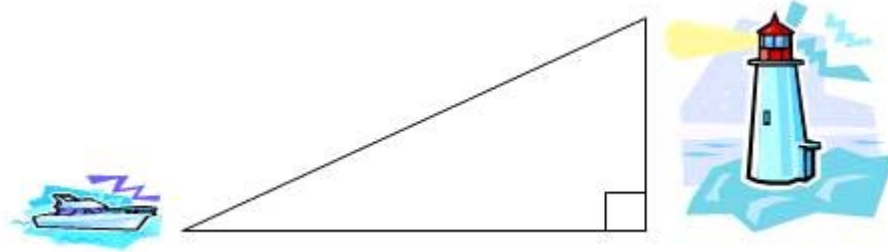

- A) 95.3 feet
- B) 107 feet
- C) 187.1 feet
- D) 412 feet

30. $\triangle ABC$ and point E are shown in the diagram below.

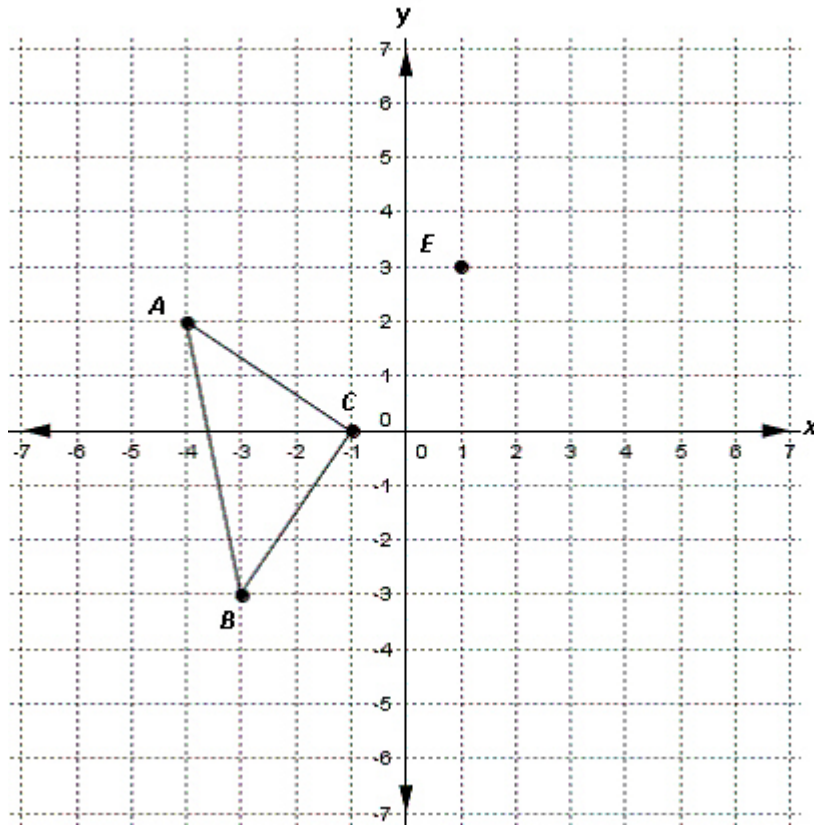

Determine a possible location of point D to make $\triangle ABC \cong \triangle CDE$.

- A) (2, 2)
 - B) (4, 1)
 - C) (3, 1)
 - D) (4, 2)
31. Given quadrilateral $ABCD$, where $\overline{AB} \parallel \overline{CD}$, $\angle ABC \cong \angle CDA$, and a diagonal \overline{AC} . Which method can be used to prove $\triangle ABC \cong \triangle CDA$?

- A) Angle-Angle-Side (AAS)
- B) Side-Side-Angle (SSA)
- C) Side-Angle-Side (SAS)
- D) Side-Side-Side (SSS)

32. Scott swims across a river that is 400 meters wide. He begins swimming perpendicular to the shore he started from but ends up 100 meters down river from where he started because of the current. How far did he actually swim from his starting point?

- A) 300 m
- B) 387.3 m
- C) 412.3 m
- D) 500 m

33. A tiled floor consists of a tessellating pattern of two regular polygons. A portion of the tiled floor is shown below.

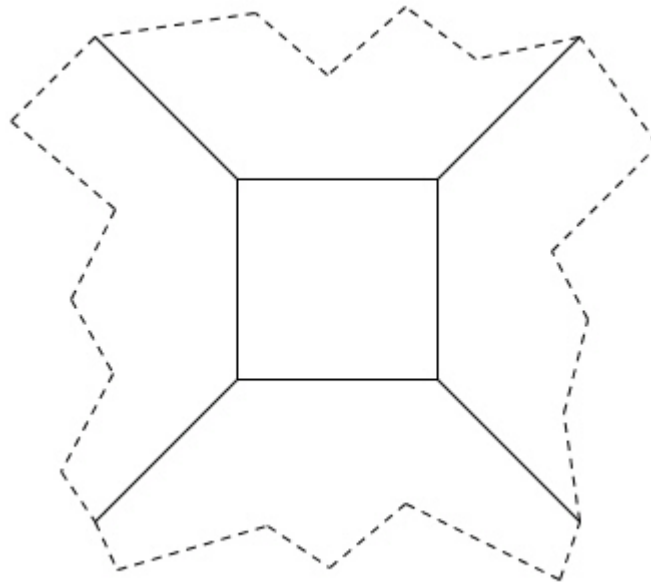

What two regular polygons are used in the tessellating pattern?

- A) Octagons and Squares
- B) Hexagons and Squares
- C) Pentagons and Squares
- D) Decagons and Squares

34. In the drawing, $ABCD$ is a parallelogram. What must be the coordinates of the intersection of the diagonals?

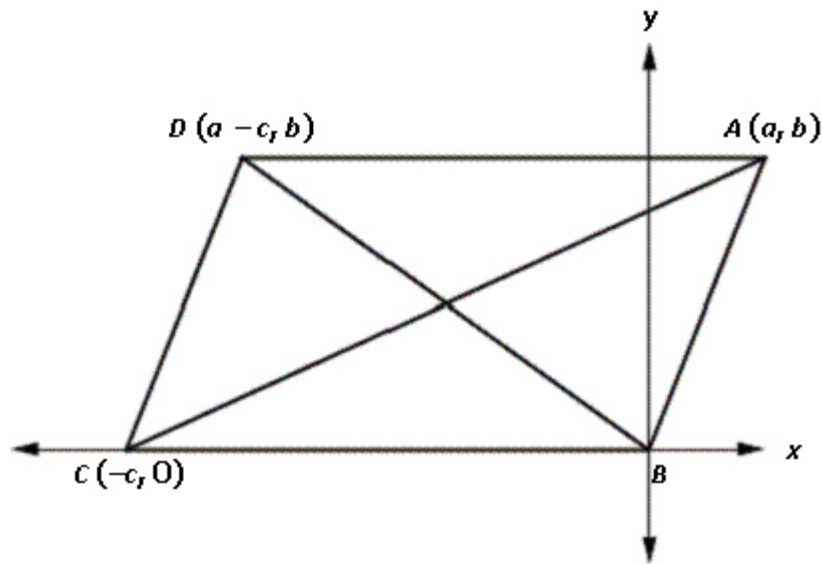

- A) $\left(\frac{a}{2}, \frac{b}{2}\right)$
 B) $\left(\frac{a-c}{2}, \frac{b+c}{2}\right)$
 C) $\left(\frac{a+c}{2}, \frac{b}{2}\right)$
 D) $\left(\frac{a-c}{2}, \frac{b}{2}\right)$

35. The exterior angle of a certain regular polygon is 60° . How many sides does the polygon have?

- A) 3
 B) 6
 C) 10
 D) 12

36. A city park can be represented by trapezoid $DEFG$, where $\overline{DE} \parallel \overline{FG}$, and \overline{DF} and \overline{EG} represent hiking paths that span the diagonals of the park.

A planning team is interested in planting additional trees throughout the park and has measured some of the angles between the edges of the park and the sidewalks as shown in the diagram below to determine the best location for the trees.

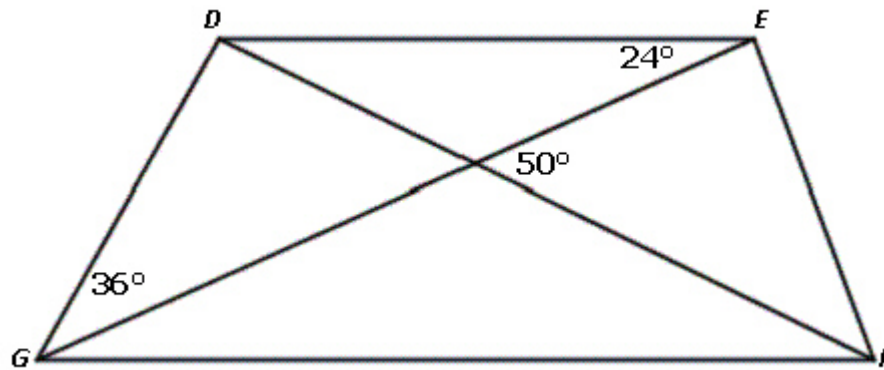

Using the information in the diagram, find $m\angle DFG$.

- A) 24°
- B) 26°
- C) 36°
- D) 50°

37. Rectangle $QRST$ is shown.

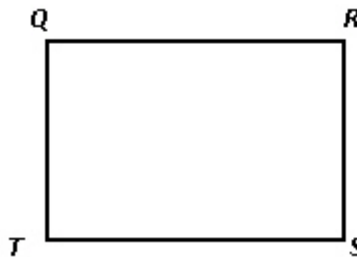

Which of the following would be a reason to claim that $QRST$ is NOT a square?

- A) $QS = RT$
- B) $QT \neq QR$
- C) $\overline{QT} \perp \overline{TS}$
- D) $\overline{QR} \parallel \overline{TS}$

38. In square $ABCD$, $AC = 3x - 4$ and $BE = x + 6$, where E is the intersection of the diagonals.

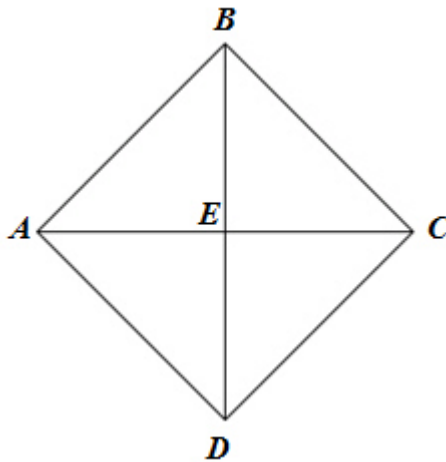

What is the length of \overline{AC} ?

- A) 11
- B) 16
- C) 22
- D) 44

39. $\triangle ABC$ is inscribed in circle O , and \overline{AB} passes through O .

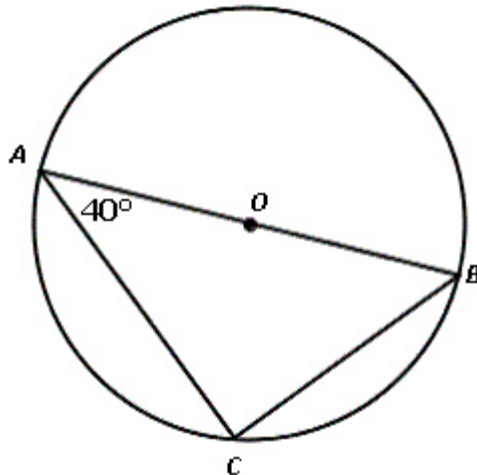

If $m\angle BAC = 40^\circ$, find $m\widehat{AC}$.

- A) 40°
 - B) 80°
 - C) 100°
 - D) 120°
40. A circle has center $(-2, 3)$ and radius 4 units. Which of the following is a point on the circle?
- A) $(-2, 5)$
 - B) $(-2, -1)$
 - C) $(2, 7)$
 - D) $(-6, 7)$
41. At Greg's Greek Gourmet, diners have an opportunity to throw a dart at a dartboard to earn a discount on their meal. The dartboard is a circle with

radius of 8 cm and is divided into two sectors. Darts that land in the unshaded sector get a free meal, and darts that land in the shaded sector get \$5 off. The dartboard is modeled by circle O below.

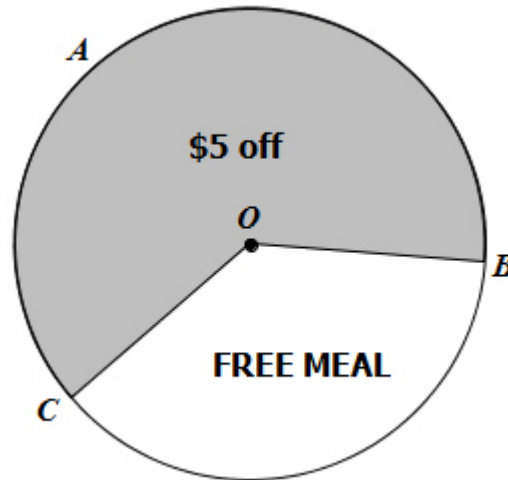

If $m\widehat{BC} = 135^\circ$, find the area of the dartboard that corresponds to a \$5 discount.

- A) $6\pi \text{ cm}^2$
- B) $10\pi \text{ cm}^2$
- C) $24\pi \text{ cm}^2$
- D) $40\pi \text{ cm}^2$

42. The coordinates of the endpoints of a diameter of a circle are $(6, 2)$ and $(0, -2)$. Which of the following is an equation of the circle?

- A) $(x - 3)^2 + y^2 = 13$
- B) $x^2 + (y - 3)^2 = 13$
- C) $(x - 3)^2 + y^2 = 52$
- D) $x^2 + (y - 3)^2 = 52$

43. A spotlight, located at point S in the diagram below, illuminates parts of a circular pond. Light is beamed at an angle of 25° from the spotlight and intercepts the circle such that the $m\widehat{BC} = 40^\circ$.

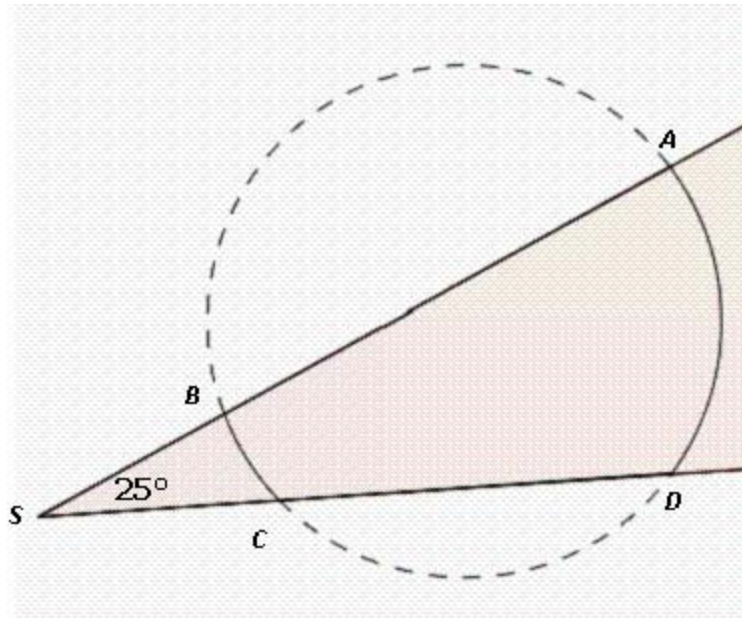

Find $m\widehat{AD}$.

- A) 50°
- B) 65°
- C) 90°
- D) 115°

44. In circle P , \overline{AD} is a diameter and \overline{BC} is perpendicular to \overline{AD} at E . If $PD = 7$ and $AE = 4$, find CE .

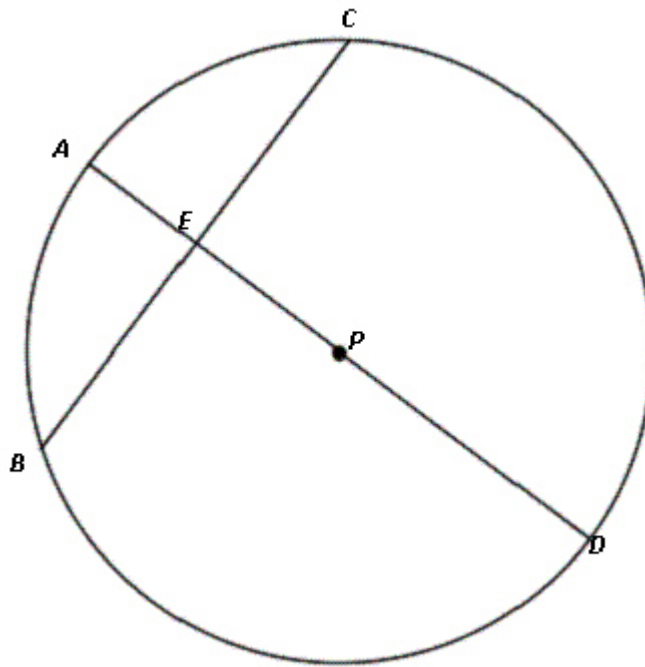

- A) $2\sqrt{7}$
- B) $2\sqrt{10}$

- C) 5.5
 D) 7

45. In circle P , \overleftrightarrow{TD} and \overleftrightarrow{TB} intersect at T . $TA=10$, $TC=8$, $CD=12$, and $AB=x+2$. Find AB .

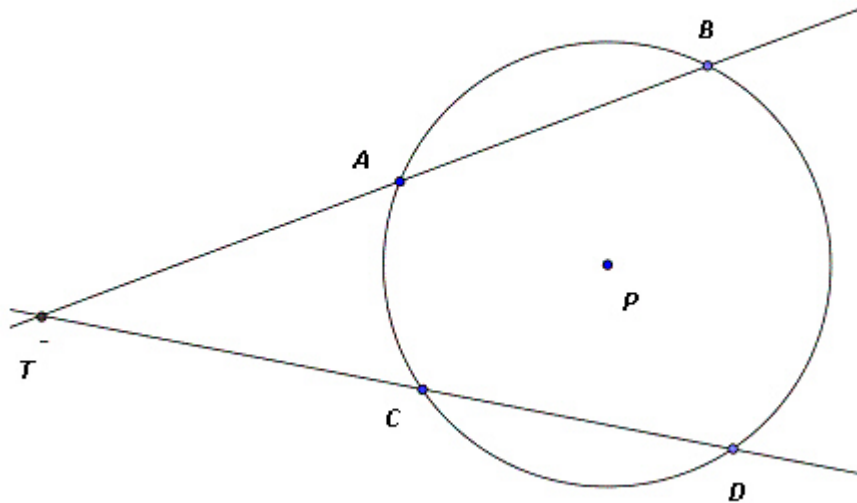

- A) 4
 B) 6
 C) 9.6
 D) 15
46. Lea made two candles in the shape of right rectangular prisms. The first candle is 15 cm high, 8 cm long, and 8 cm wide. The second candle is 5 cm taller but has the same length and width. How much additional wax was needed to make the taller candle?
- A) 320 cm^3
 B) 640 cm^3
 C) 960 cm^3
 D) 1280 cm^3
47. A tepee with a dirt floor in the shape of a right cone has a slant height of 26 feet and a radius of 12.5 feet. Approximately how much canvas would be needed to cover the tepee?

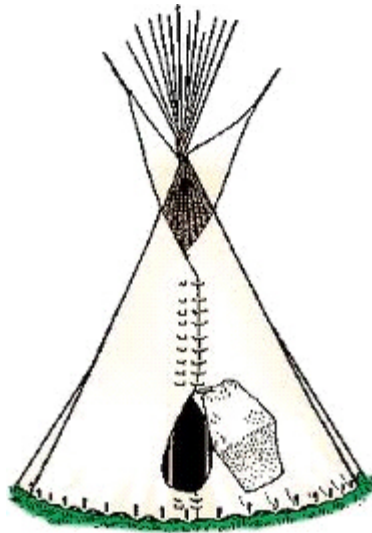

- A) 3730 sq ft
- B) 4254 sq ft
- C) 1511 sq ft
- D) 1021 sq ft

48. The ratio between the volumes of two cubes is 125 to 216. What is the ratio between their respective surface areas?

- A) 5:6
- B) 25:36
- C) 125:216
- D) 250:432

49. Which of the following would triple the volume of the Egyptian square-based Pyramid below?

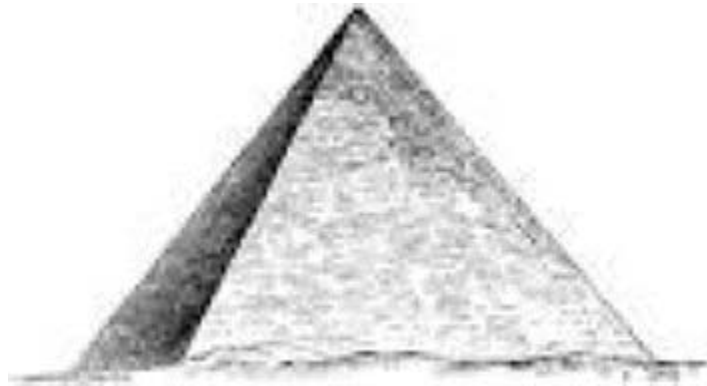

- A) add 3 to each dimension of the Pyramid
- B) multiply every dimension of the Pyramid by 3
- C) multiply only the height by 3
- D) add 3 to the slant height

50. Which of the following three-dimensional shapes have equivalent surface areas?

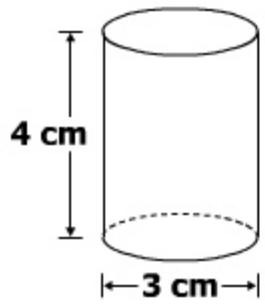

Figure 1

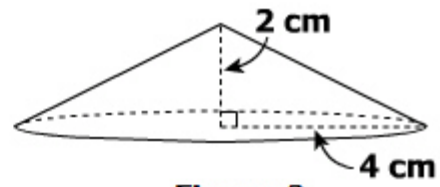

Figure 2

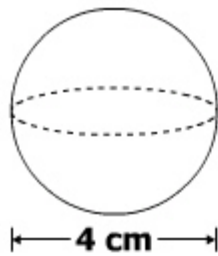

Figure 3

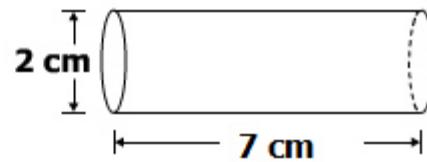

Figure 4

- A) Figures 1 and 2
- B) Figures 2 and 3
- C) Figures 3 and 4
- D) Figures 1 and 4

Done

Show/Hide Answers